

7.5A Low Dropout Positive Adjustable Regulator

DESCRIPTION

The RH1083M positive adjustable regulator is designed to provide 7.5A with higher efficiency than currently available devices. All internal circuitry is designed to operate down to 1V input-to-output differential and the dropout voltage is fully specified as a function of load current. Dropout is guaranteed at a maximum of 1.5V at maximum output current, decreasing at lower load currents. On-chip trimming adjusts the output voltage to 1%. Current limit is also trimmed, minimizing the stress on both the regulator and power source circuitry under overload conditions.

The RH1083M is pin compatible with older 3-terminal regulators. A 10 μ F output capacitor is required on this new device. However, this is usually included in most regulator designs.

Unlike PNP regulators, where up to 10% of the output current is wasted as quiescent current, the RH1083M quiescent current flows into the load, increasing efficiency.

The wafer lots are processed to Linear Technology Corporation's in-house Class S flow-to-yield circuits usable in stringent military applications.

Since the TO-3 package on this product cannot meet the cracked glass external visual criteria of MIL-STD-883 Method 2009, inspection for cracked glass at 100% external visual will not be performed. Instead a 100% fine/gross leak test will be performed just prior to shipment.

ABSOLUTE MAXIMUM RATINGS

Power Dissipation	Internally Limited
Input-to-Output Voltage Differential	30V
Operating Junction Temperature Range	
Control Circuitry	-55°C to 150°C
Power Transistor	-55°C to 200°C
Storage Temperature Range	-65°C to 150°C
Lead Temperature (Soldering, 10 sec.)	300°C

 LTC and LT are registered trademarks of Linear Technology Corporation.

BURN-IN CIRCUIT

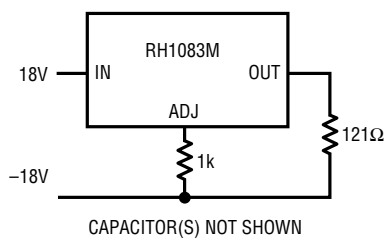

RH1083 BI

PACKAGE INFORMATION

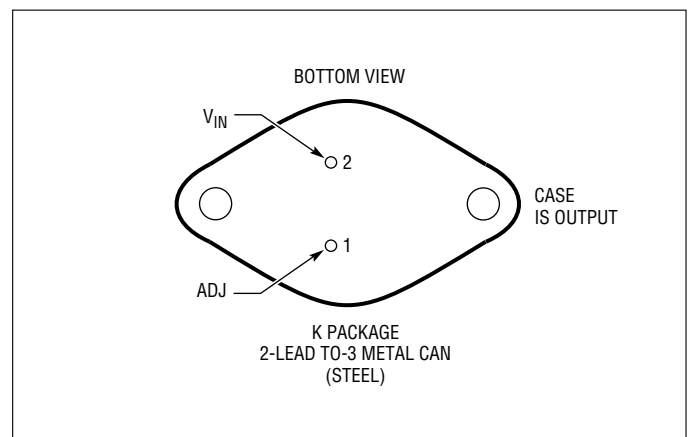

TABLE 1: ELECTRICAL CHARACTERISTICS (Preirradiation)

PARAMETER	CONDITIONS	NOTES	T _J = 25°C			SUB-GROUP	-55°C ≤ T _J ≤ 125°C			SUB-GROUP	UNITS
			MIN	TYP	MAX		MIN	TYP	MAX		
Reference Voltage	I _{OUT} = 10mA, (V _{IN} - V _{OUT}) = 3V	3	1.238	1.250	1.262	1					V
	10mA ≤ I _{OUT} ≤ I _{FULLLOAD} , 1.5V ≤ (V _{IN} - V _{OUT}) ≤ 25V						1.225	1.250	1.270	2,3	V
Line Regulation	I _{LOAD} = 10mA 1.5V ≤ (V _{IN} - V _{OUT}) = 15V 15V ≤ (V _{IN} - V _{OUT}) = 30V	1,2		0.015	0.2	1		0.035	0.2	2,3	%
						1		0.05	0.5	2,3	%
Load Regulation	(V _{IN} - V _{OUT}) = 3V 10mA ≤ I _{OUT} ≤ I _{FULLLOAD}	1,2,3		0.1	0.3	1		0.2	0.4	2,3	%
Dropout Voltage	ΔV _{REF} = 1%, I _{OUT} = I _{FULLLOAD}	4			1.5	1		1.3	1.5	2,3	V
Current Limit	(V _{IN} - V _{OUT}) = 5V (V _{IN} - V _{OUT}) = 25V		8.0			1	8.0	9.5		2,3	A
			0.4			1	0.4	1.0		2,3	A
Minimum Load Current	(V _{IN} - V _{OUT}) = 25V				10	1		5.0	10	2,3	mA
Thermal Regulation	T _A = 25°C, 30ms Pulse			0.002	0.010	1					%/W
Ripple Rejection	f = 120Hz, C _{ADJ} = 25μF, C _{OUT} = 25μF Tantalum, I _{OUT} = I _{FULLLOAD} (V _{IN} - V _{OUT}) = 3V		60			4	60	75		5,6	dB
Adjust Pin Current				55	120	1			120	2,3	μA
Adjust Pin Current Change	10mA ≤ I _{OUT} ≤ I _{FULLLOAD} , 1.5V ≤ (V _{IN} - V _{OUT}) ≤ 25V				5	1		0.2	5.0	2,3	μA
Temperature Stability								0.5			%
Long-Term Stability	T _A = 125°C, 1000 Hours							0.3			%
RMS Output Noise (% of V _{OUT})	T _A = 25°C, 10Hz ≤ f ≤ 10kHz			0.003							%
Thermal Resistance Junction-to-Case	Control Circuitry	5			0.6						°C/W
	Power Transistor	5			1.6						°C/W

TOTAL DOSE BIAS CIRCUIT

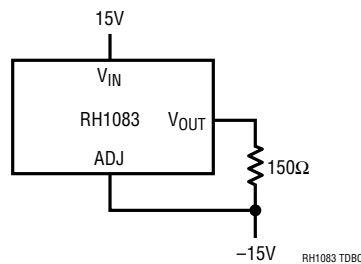

TABLE 1A: ELECTRICAL CHARACTERISTICS (Postirradiation)

PARAMETER	CONDITIONS	10KRAD(Si)		20KRAD(Si)		50KRAD(Si)		100KRAD(Si)		200KRAD(Si)		UNITS
		MIN	MAX	MIN	MAX	MIN	MAX	MIN	MAX	MIN	MAX	
Reference Voltage (Note 3)	$I_{OUT} = 10\text{mA}$ ($V_{IN} - V_{OUT} = 3\text{V}$)	1.234	1.258	1.232	1.257	1.227	1.253	1.223	1.247	1.216	1.241	V
	$10\text{mA} \leq I_{OUT} \leq I_{FULLLOAD}$ $1.5\text{V} \leq (V_{IN} - V_{OUT}) \leq 15\text{V}$	1.210	1.275	1.219	1.275	1.215	1.275	1.210	1.275	1.203	1.275	V
Line Regulation (Notes 1, 2)	$I_{OUT} = 10\text{mA}$											
	$1.5\text{V} \leq (V_{IN} - V_{OUT}) \leq 15\text{V}$		0.2		0.21		0.23		0.25		0.3	%
	$15\text{V} \leq (V_{IN} - V_{OUT}) \leq 30\text{V}$		0.5		0.5		0.5		0.5		0.5	%
Load Regulation (Notes 1, 2, 3)	$(V_{IN} - V_{OUT}) = 3\text{V}$ $10\text{mA} \leq I_{OUT} \leq I_{FULLLOAD}$		0.3		0.3		0.3		0.35		0.4	%
Dropout Voltage (Note 4)	$\Delta V_{REF} = 1\%$, $I_{OUT} = I_{FULLLOAD}$		1.5		1.55		1.65		1.8		2.0	V
Current Limit	$(V_{IN} - V_{OUT}) = 5\text{V}$	8		8		7.95		7.85		7.75		V
	$(V_{IN} - V_{OUT}) = 25\text{V}$	0.4		0.4		0.4		0.4		0.4		V
Minimum Load Current	$(V_{IN} - V_{OUT}) = 25\text{V}$		10		10		10		10		10	mA
Adjust Pin Current			120		120		120		120		120	μA
Adjust Pin Current Change (Note 5)	$10\text{mA} \leq I_{OUT} \leq I_{FULLLOAD}$ $1.5\text{V} \leq (V_{IN} - V_{OUT}) \leq 15\text{V}$		5		5		5		5		5	μA

Note 1: See thermal regulation specifications for changes in output voltage due to heating effects. Line and load regulation are measured at a constant junction temperature by low duty cycle pulse testing.

Note 2: Line and load regulation are guaranteed up to the maximum power dissipation of 60W for RH1083M. Power dissipation is determined by the input-to-output differential voltage and the output current. Guaranteed maximum power dissipation will not be available over the full input-to-output voltage range.

Note 3: $I_{FULLLOAD}$ is defined in the current limit curves in the standard data sheet. $I_{FULLLOAD}$ curve is defined as the minimum value of current

limit as a function of input-to-output voltage. Note that the 60W power dissipation for the RH1083M is achievable over a limited range of input-to-output voltage. For compliance with 883 revision C current density specifications, the RH1083M is rated for 5A.

Note 4: Dropout voltage is specified over the full output current range of the device. Test points and limits are shown on the Dropout Voltage curve in the standard data sheet.

Note 5: Guaranteed by design, characterization, or correlation to other tested parameters.

TABLE 2: ELECTRICAL TEST REQUIREMENTS

MIL-STD-883 TEST REQUIREMENTS	SUBGROUP
Final Electrical Test Requirements (Method 5004)	1*,2,3
Group A Test Requirements (Method 5005)	1,2,3
Group C and D End-Point Electrical Parameters (Method 5005)	1,2,3

* PDA Applies to subgroup 1. See PDA Test Notes.

PDA Test Notes

The PDA is specified as 5% based on failures from group A, subgroup 1, tests after cooldown as the final electrical test in accordance with method 5004 of MIL-STD-883 Class B. The verified failures of group A, subgroup 1, after burn-in divided by the total number of devices submitted for burn-in in that lot shall be used to determine the percent for the lot.

Linear Technology Corporation reserves the right to test to tighter limits than those given.

TYPICAL PERFORMANCE CHARACTERISTICS

